

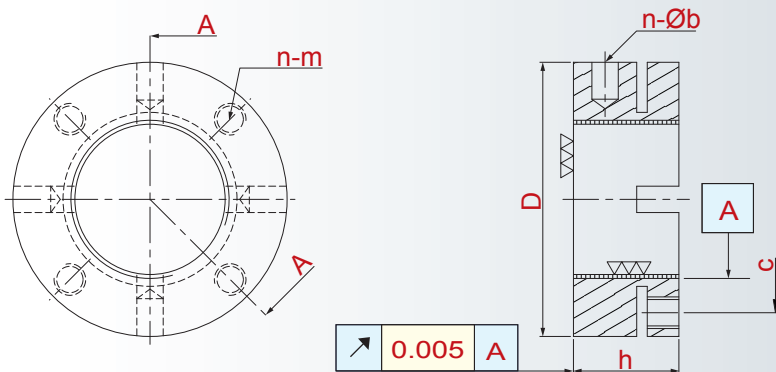

Precision Locknuts for Ballscrews, High Precision Spindles, Mechanical Transmitting Locking.

※ Screws included with this model.



YSAM locknut uses steel's elasticity characteristics to securely fix the locking nut in the axial direction.

- Material Composition: SCM440(42CrMo4)
- Hardness: HRC28°~32°
- Thread Accuracy: ISO 4H
- Manufacturing Method: High Precision Grinding
- Run Out: 0.002mm
- Thread Accuracy: ISO 4H
- Manufacturing Method: High Precision Turning
- Run Out: 0.005mm

YSAM

Thread	D	h	n-m	n-Øb	c	MAX. Nm
YSAM-M15 x 1.0P	30	18	4-M5	4-Ø4	24	4.5
YSAM-M17 x 1.0P	32	18	4-M5	4-Ø4	26	4.5
YSAM-M20 x 1.0P	38	18	4-M6	4-Ø4	31	8
YSAM-M25 x 1.5P	45	20	4-M6	4-Ø5	38	8
YSAM-M30 x 1.5P	52	20	4-M6	4-Ø5	45	8
YSAM30/65-M30 x 1.5P	65	30	4-M6	4-Ø6	45	8
YSAM-M35 x 1.5P	65	22	4-M6	4-Ø6	58	8
YSAM35/58-M35 x 1.5P	58	20	4-M6	4-Ø5	51	8
YSAM-M40 x 1.5P	65	22	4-M6	4-Ø6	58	8
YSAM40/85-M40 x 1.5P	85	32	4-M6	4-Ø6	58	8
YSAM-M45 x 1.5P	70	22	6-M6	6-Ø6	63	8
YSAM-M50 x 1.5P	75	25	6-M6	6-Ø6	68	8
YSAM-M55 x 2.0P	85	26	6-M8	6-Ø6	75	18
YSAM-M60 x 2.0P	90	26	6-M8	6-Ø6	80	18
YSAM-M65 x 2.0P	100	26	6-M8	6-Ø8	88	18
YSAM-M70 x 2.0P	100	28	6-M8	6-Ø8	90	18
YSAM-M75 x 2.0P	115	30	6-M10	6-Ø8	102	35
YSAM-M80 x 2.0P	110	30	6-M10	6-Ø8	98	35
YSAM-M85 x 2.0P	115	30	6-M10	6-Ø8	102	35
YSAM-M90 x 2.0P	130	30	6-M10	6-Ø8	118	35
YSAM-M100 x 2.0P	130	30	8-M10	8-Ø8	118	35
YSAM-M110 x 2.0P	140	30	8-M10	8-Ø8	128	35
YSAM-M120 x 2.0P	155	30	8-M10	8-Ø8	142	35
YSAM-M130 x 2.0P	165	30	8-M10	8-Ø8	152	35