

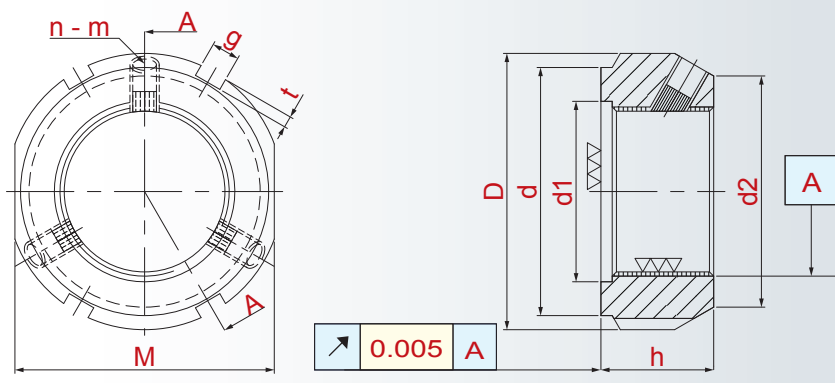

**Precision Locknuts** for Ballscrews, High Precision Spindles, Mechanical Transmitting Locking.

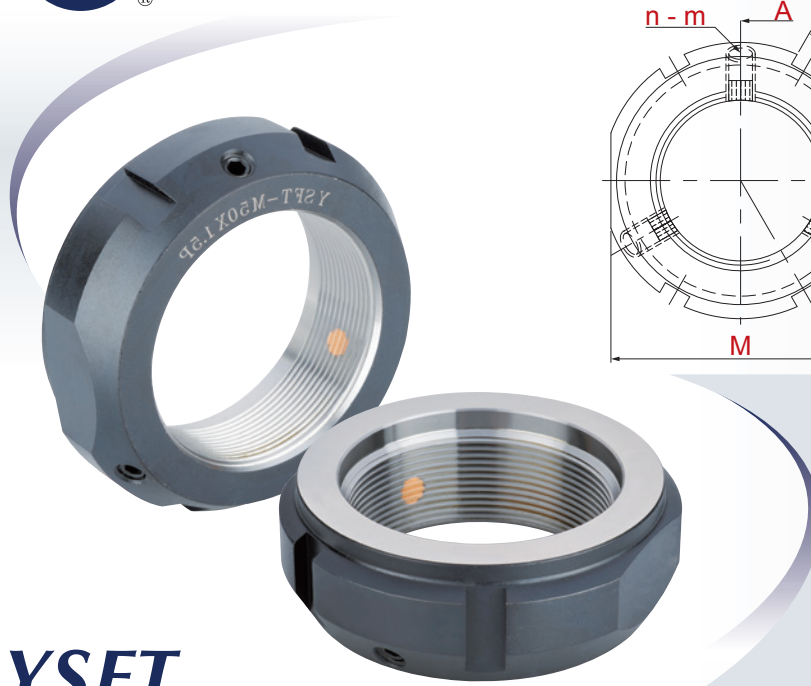

YSFT Locks the threads from 30° angle direction with three point locks. The advantages of this design is the brass locking threads can fully contact with male threads, thus ensuring the assembled accuracy.

- Material Composition: SCM440(42CrMo4)
- Hardness: HRC28°~32°
- Thread Accuracy: ISO 4H
- Manufacturing Method: High Precision Grinding
- Run Out: 0.002mm
- Thread Accuracy: ISO 4H
- Manufacturing Method: High Precision Turning
- Run Out: 0.005mm

# YSFT

Thread	D	h	g	t	d	d1	d2	M	n-m	MAX. Nm
YSFT-M10 x 0.75P	28	14	4	2	23	11	21	24	3 - M5	4.5
YSFT-M12 x 1.0P	30	14	4	2	25	13	23	27	3 - M5	4.5
YSFT-M15 x 1.0P	33	16	4	2	28	16	26	30	3 - M5	4.5
YSFT-M17 x 1.0P	37	18	5	2	33	18	29	34	3 - M6	8
YSFT-M20 x 1.0P	40	18	5	2	35	21	32	36	3 - M6	8
YSFT-M25 x 1.5P	44	20	5	2	39	26	36	41	3 - M6	8
YSFT-M30 x 1.5P	49	20	5	2	44	32	41	46	3 - M6	8
YSFT-M35 x 1.5P	54	22	5	2	49	38	46	50	3 - M6	8
YSFT-M40 x 1.5P	65	22	6	2.5	59	42	56	60	3 - M6	8
YSFT-M45 x 1.5P	70	22	6	2.5	64	48	61	65	3 - M6	8
YSFT-M50 x 1.5P	75	25	7	3	68	52	65	70	3 - M6	8
YSFT-M55 x 2.0P	85	25	7	3	78	58	74	80	3 - M8	18
YSFT-M60 x 2.0P	90	26	8	3.5	82	62	78	85	3 - M8	18
YSFT-M65 x 2.0P	95	28	8	3.5	87	68	83	90	3 - M8	18
YSFT-M70 x 2.0P	100	28	8	3.5	92	72	88	95	3 - M8	18
YSFT-M75 x 2.0P	105	28	8	3.5	97	77	93	100	3 - M8	18
YSFT-M80 x 2.0P	110	32	8	3.5	100	83	98	-	3 - M8	18
YSFT-M85 x 2.0P	120	32	10	4	110	88	107	-	3 - M10	35
YSFT-M90 x 2.0P	125	32	10	4	115	93	112	-	3 - M10	35
YSFT-M95 x 2.0P	130	32	10	4	120	98	117	-	3 - M10	35
YSFT-M100 x 2.0P	135	32	10	4	125	103	122	-	3 - M10	35
YSFT-M110 x 2.0P	145	32	10	4	134	112	132	-	3 - M10	35
YSFT-M120 x 2.0P	155	32	10	4	144	122	142	-	3 - M10	35
YSFT-M130 x 2.0P	165	32	12	5	154	132	152	-	3 - M10	35
YSFT-M140 x 2.0P	175	32	14	6	164	142	162	-	3 - M10	35
YSFT-M150 x 2.0P	185	32	14	6	174	152	172	-	3 - M10	35
YSFT-M160 x 3.0P	195	32	14	6	184	162	182	-	3 - M10	35
YSFT-M170 x 3.0P	205	32	14	6	194	172	192	-	3 - M10	35
YSFT-M180 x 3.0P	215	32	16	7	204	182	202	-	3 - M10	35
YSFT-M190 x 3.0P	225	32	16	7	214	192	212	-	3 - M10	35
YSFT-M200 x 3.0P	235	32	18	8	224	202	222	-	3 - M10	35